

MY HIGH-LEVEL OKRs + WHY!

Directions

- Glance at these pages, print the layouts you want.
- Fill them out with your Dreams.
- Remember
 - OKRs = Objective + 2 or 3 Key Results
 - Each OKR is powered by a Big WHY.
 - Objective is what you want. (Your Dream/Vision)
 - Key Results MUST be measurable, and results driven.
 - Usually, numbers that can't be changed in a day.
 - Projects MUST drive parent OKR's Numbers.
 - MUST be numbers you can control today.
 - Less is more. Fewer OKRs & Projects = More Focus.
 - Make sure all projects and OKRs have DEADLINES.
- Example:

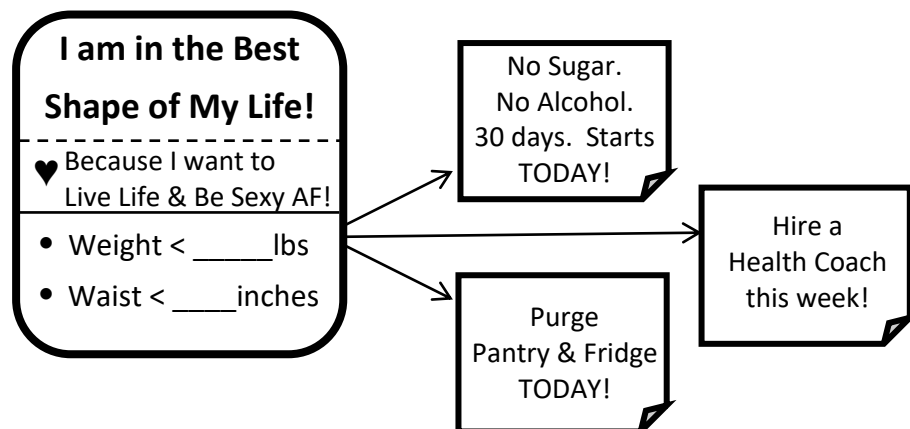
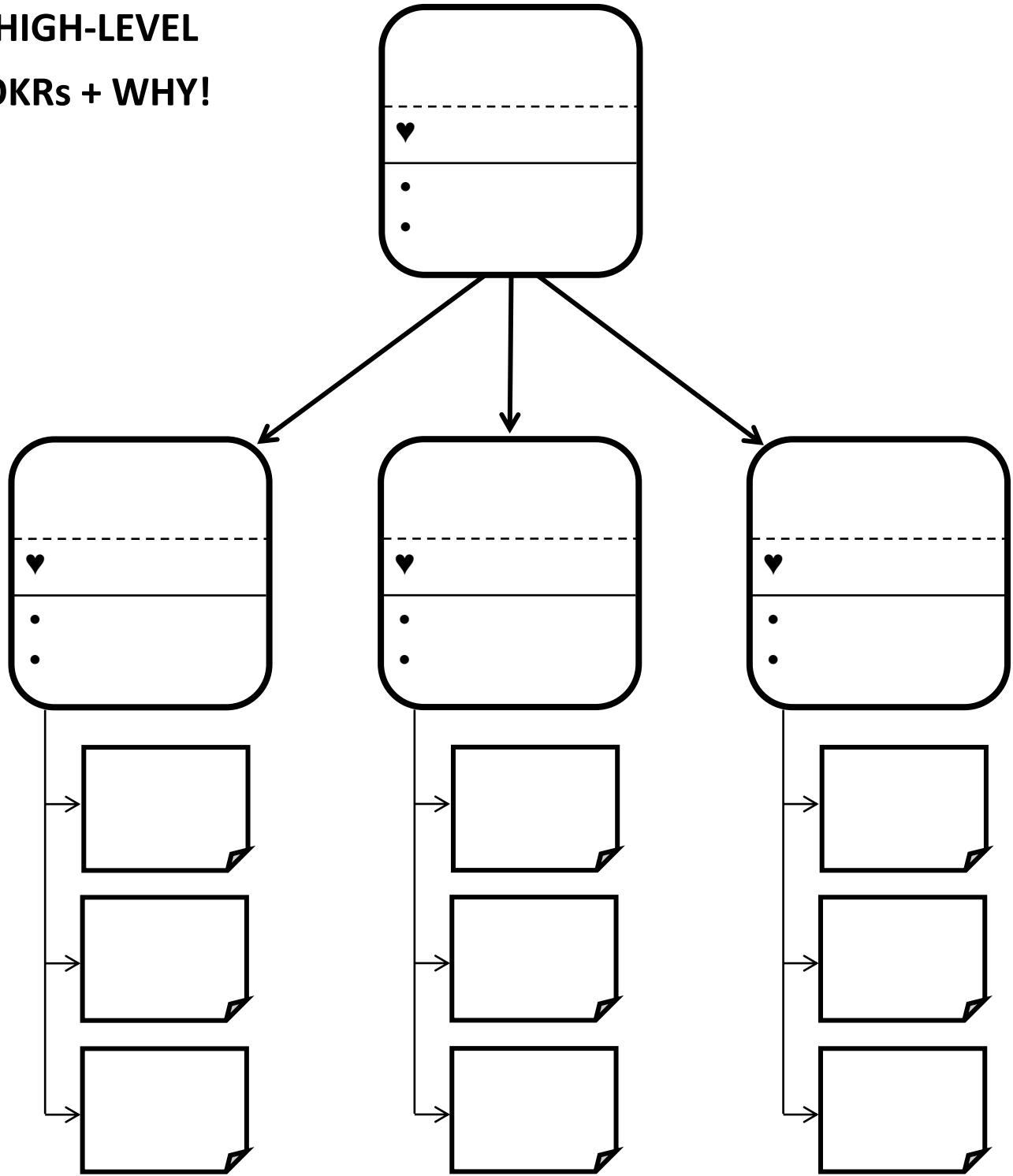

**HIGH-LEVEL
OKRs + WHY!**



HIGH-LEVEL OKRs + WHY!

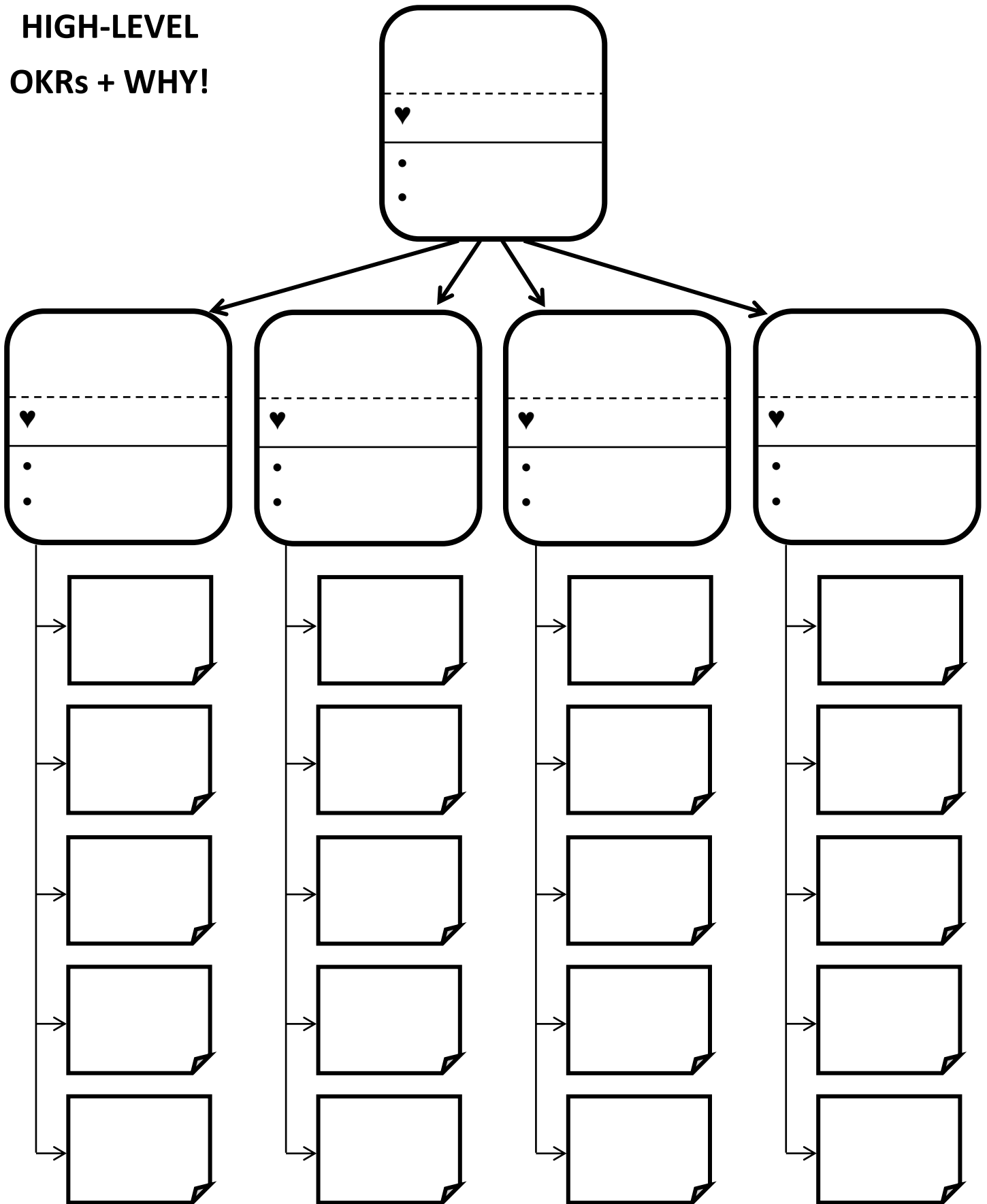

HIGH-LEVEL OKRs + WHY!

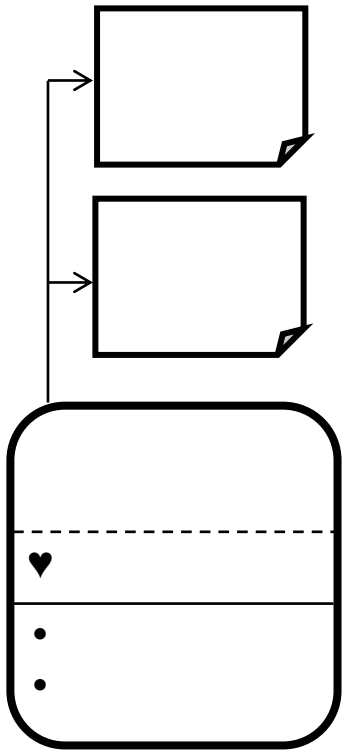
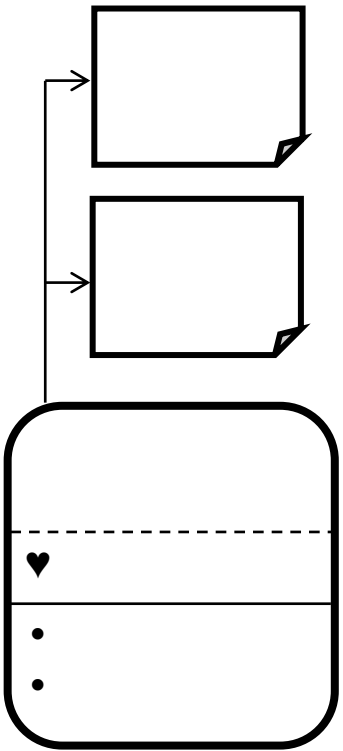
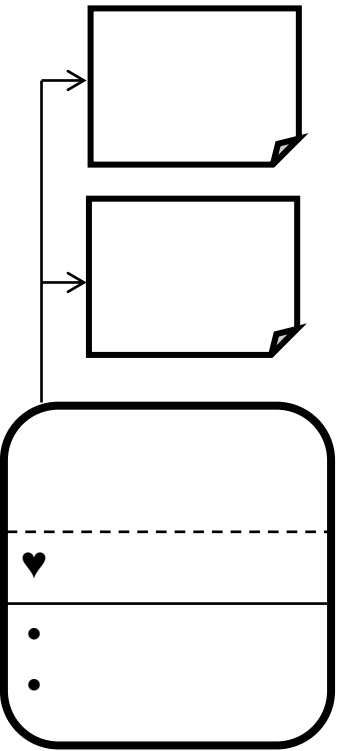
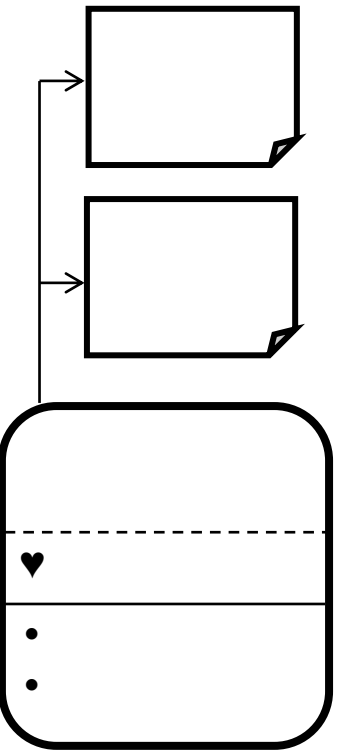
			
--	--	---	--

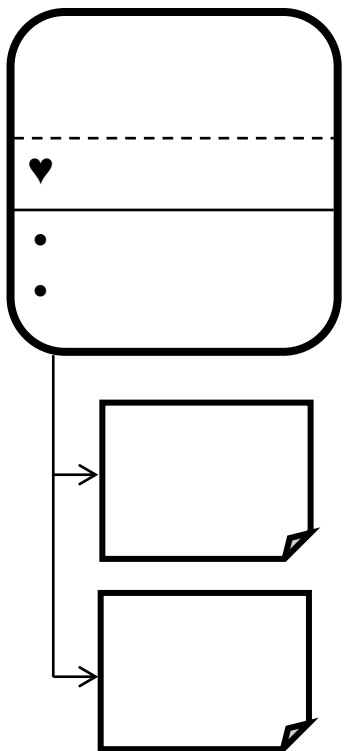
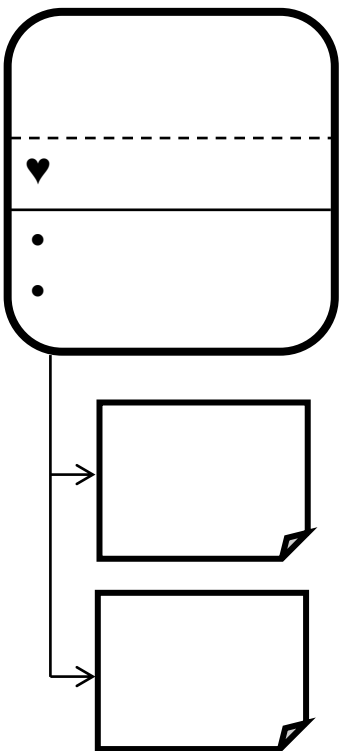
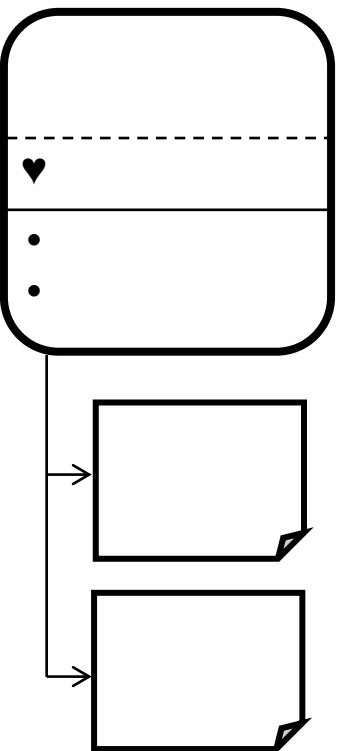
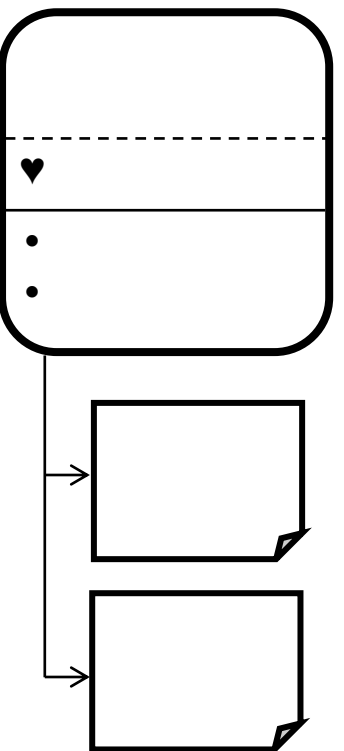
			
---	---	--	---

**HIGH-LEVEL
OKRs + WHY!**

